

# Dual Hose Propane Fuel Dispenser

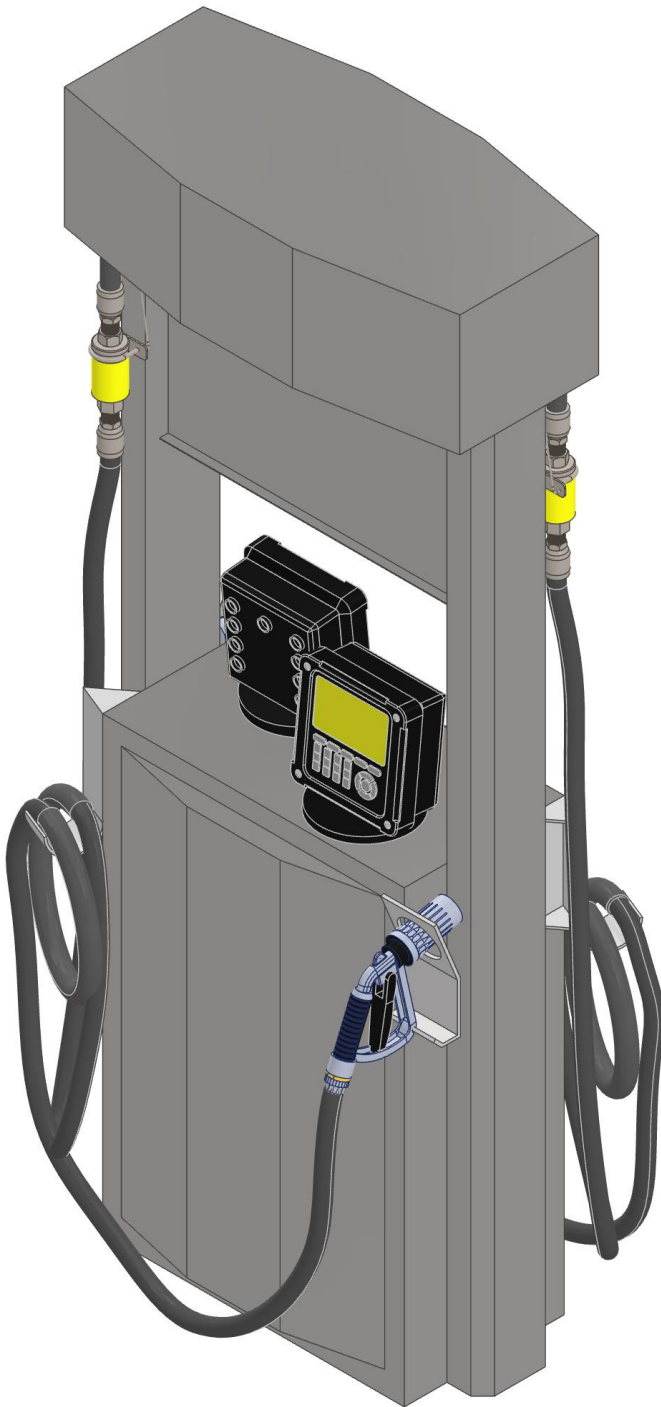

The Dual Hose Propane Fuel Dispenser for Autogas fleets provides the most reliable, safe and accurate refueling capabilities for your propane fleet.

Our advanced design provides ease of operation, completely automated and dependable. Also designed to be compatible with any fuel management system.

Moreover, our stainless steel dispenser offers the best corrosion resistance and durability for the harshest environments.

## STANDARD FEATURES:

- Configurable interface and completely automated operation with Liquid Controls LRCiQ register.
- Precise flow measurement with Liquid Controls MA-4 tri-rotor meter, enabling accurate refueling with quick and safe high-pressure liquid transfer.
- Automatic valve and pump control streamline the fueling process, maximizing safety and productivity while minimizing risk of error.
- Fueling capacity of up to 30 GPM
- Temperature range from -40° to 160° F
- European nozzle complies with latest Autogas requirements and makes connection and disconnection easier.

Our dispensers are designed and manufactured to the highest standards with compliance to the motor fuel, LPG and fuel gas codes to ensure highest performance while offering unparalleled safety.

Cutting-edge dispenser that guarantees maximum security and performance

DATA SHEET REV. 1.2  
PFS-DS-DH-SS

# DUAL HOSE DISPENSER

Part List	
ITEM	DESCRIPTION
1	LCR.iQ Electronic Register
2	MA-4 Dual Meter
3	Elaflex ZVG-2 Euro Nozzle
4	Elaflex 15 ft long Hose

## DIMENSIONS

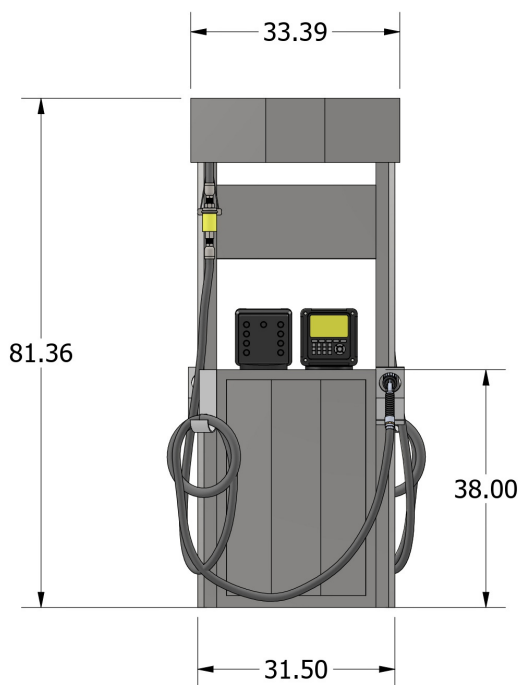

FRONT VIEW

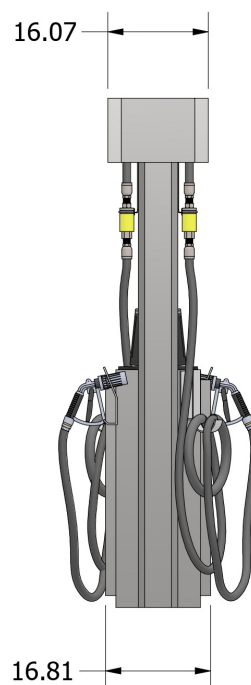

LATERAL VIEW

